



Cable and pipe seals for underground applications



Sealing solutions against constant water pressure

Do you want to prevent water ingress? Use Roxtec seals to avoid the risk of costly downtime and power outages due to corrosion, damage to equipment or partial discharge.

Roxtec UG™ (underground) solutions for cables and pipes protect your site against environmental ingress in both normal and flood conditions. The seals withstand cable bending forces and are resistant to

constant water pressure. Keep your equipment dry and safe by ensuring a long-lasting sealing barrier against flooding, gas, humidity and rodents.

User-friendly flexibility

Roxtec UG™ seals are easy to install even in wet conditions and in environments with running water.

- Available for single or multiple cables and pipes
- Multidiameter™ by Roxtec – adapts to cable and pipe sizes through removable layers
- Built-in spare capacity for future needs



Retention capabilities

The seals are tested and developed to provide excellent cable retention.

- Withstands pull force of up to 15 000 N and a weight load of up to 1 500 kg
- Withstands extreme cable bending
- Can expand up to 5 mm to aid installation and ensure a perfect fit

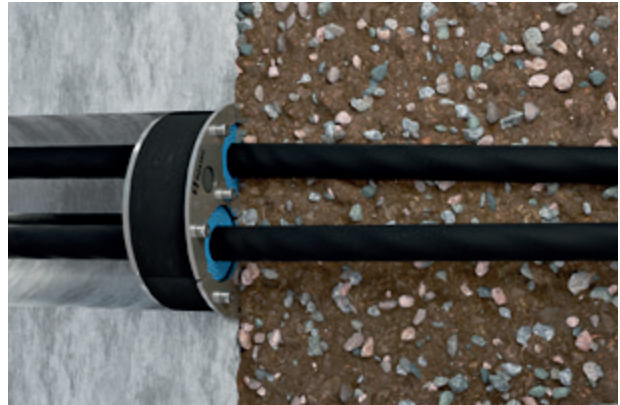

Tight and resistant

Roxtec UG™ solutions are IP 68 rated. They are tested for constant and catastrophic water pressure. Thanks to their high grade acid-proof stainless steel, they are suitable for the harshest of environments.

- Constant water pressure up to 0.5 bar (5 mH₂O)
- Catastrophic water pressure up to 1 bar (10 mH₂O)
- Gas pressure up to 0.3 bar
- Corrosion and rodent safe

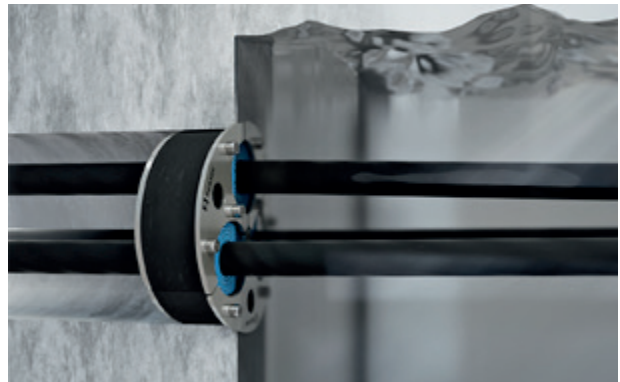

Maintain optimum operating conditions.

roxtec.com/ug

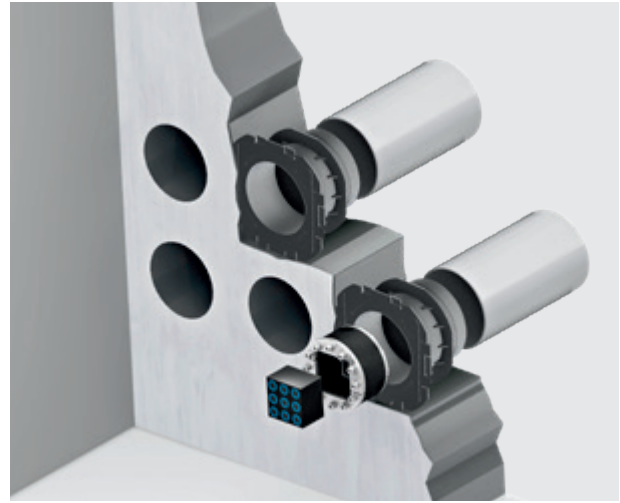
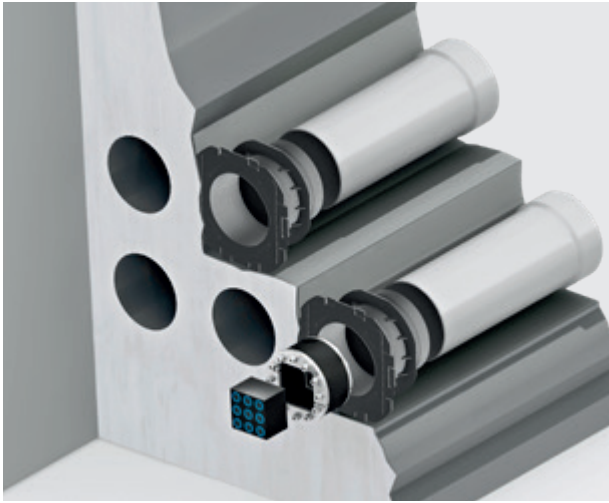

Knock-out sleeve providing spare capacity

Use the Roxtec knock-out sleeve to block openings you might want to use later on. Plan your ducted openings, with the added benefit that any spare or unused duct is sealed without additional cost. You only need to buy seals for openings that accommodate cables. This is an area efficient solution for reducing the footprint and for making sure the building is dry both during and after construction.

Think first

Include knock-out sleeves in the design work for a new building or kiosk. You decide if you want the seal on the inside or the outside and whether you want to connect sleeves into a cluster of openings. Then cast the sleeves into the structure, and knock them out when needed. Use sleeves to ensure consistent results in terms of position and formation of holes and avoid deformed ducts.

Basic steps of a Roxtec knock-out sleeve installation

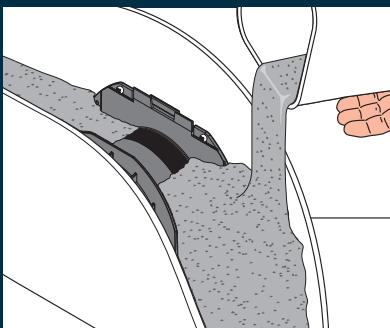

Pour concrete into the mould.

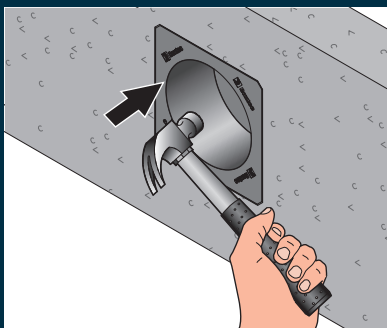

Knock out the lid.

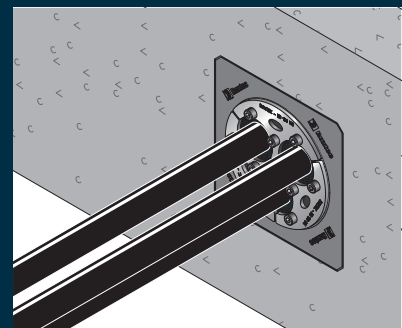

Insert the Roxtec seal.



Adaptable and tailor-made solutions

Roxtec UG™ solutions are perfect for use around existing cables and pipes, and the smart design simplifies retrofit. The seals fit into the knock-out sleeve as well as in conduits and core drilled holes. The soft yet firm rubber adapts to uneven openings and ducts. Our openable seals do not suffer from failure in the same way as traditional methods do when the cables or pipes move and expand.

Customized seals

If you have specific needs or face challenges that require special Roxtec UG™ seals, our design and engineering team is ready to help you by creating tailor-made sealing solutions.

Basic steps of a Roxtec RS UG™ seal installation

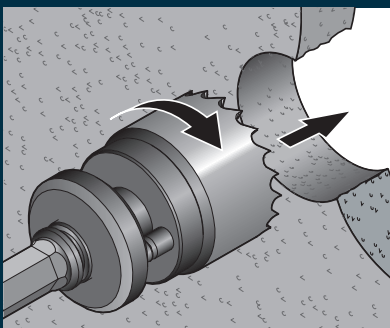

Make an aperture with a core drill.

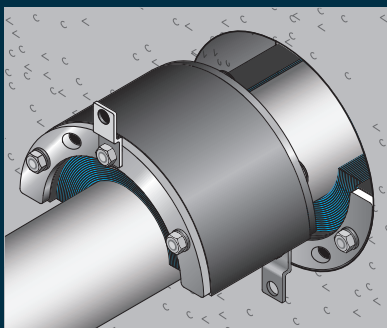

Insert pipe and RS UG halves.

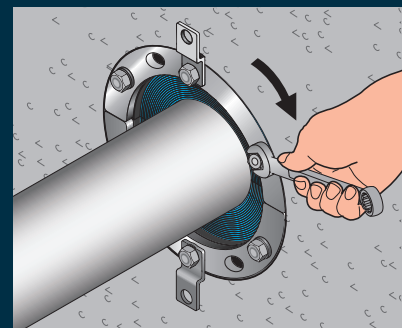

Tighten the seal.

Numerous application areas

Roxtec UG™ seals are ideal for cables and pipes entering buildings via concrete foundations. They provide excellent cable retention, eliminate flooding and prevent humidity from damaging equipment. You can use them in vaults, duct banks or cable trenches.

Cable types

- Power
- High voltage power
- Signaling
- Telecom

Pipe types

- District heating
- District cooling
- Water
- Wastewater
- Plastic, steel and isolated pipes

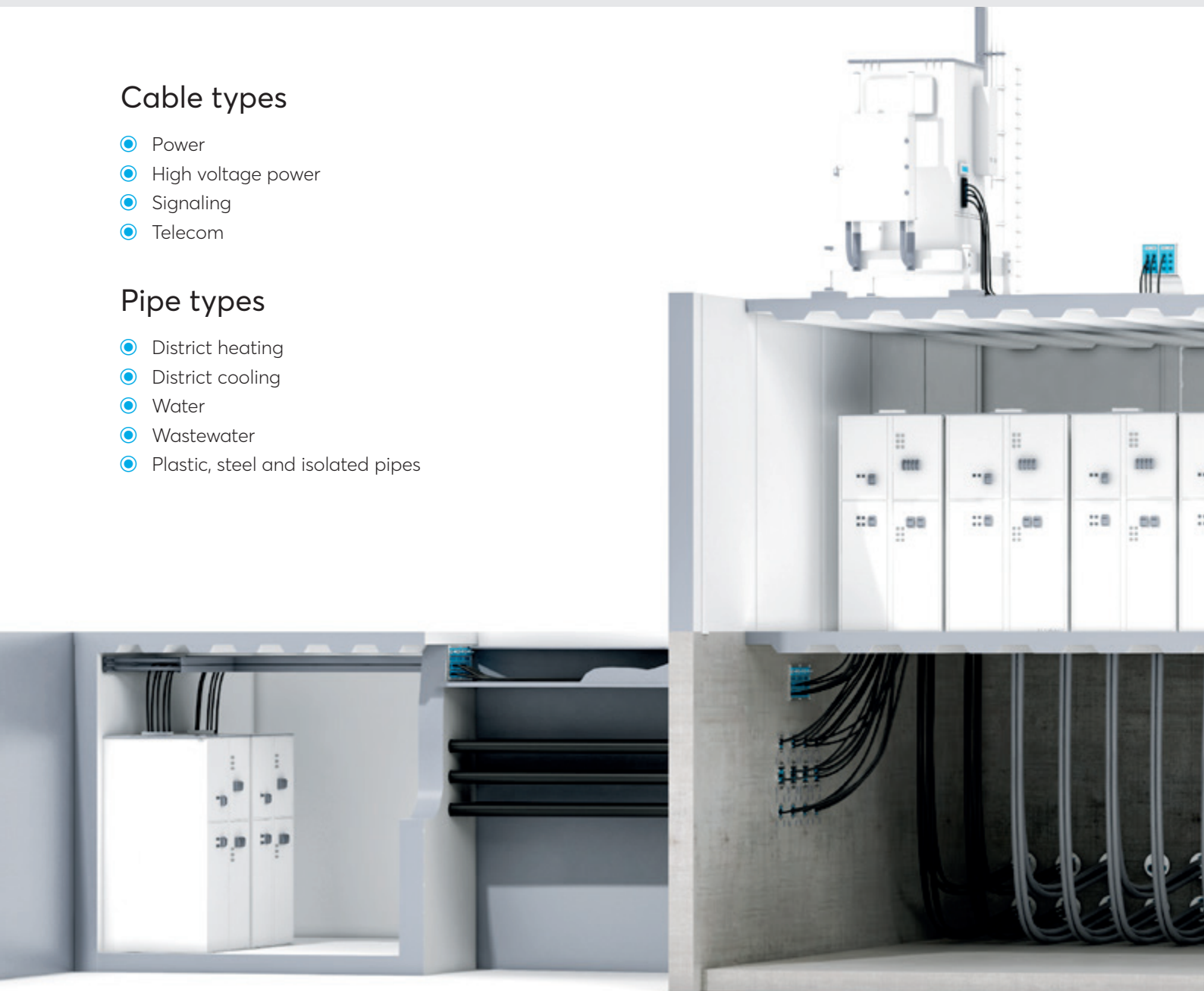



The Roxtec RS UG™ seal is designed for single cables and pipes entering buildings via foundations.



The Roxtec R UG™ transit is ideal for several cables of different sizes in one opening. It enables you to build in spare capacity.



Roxtec H3 UG™ seals are designed for cables in trefoil formations. The design simplifies retrofit installations.



The Roxtec knock-out sleeve provides spare capacity and ensures tightness prior to cable routing.



Protecting life and assets

Roxtec is the world leader within flexible cable and pipe transits. Since the start in Sweden in 1990 we have grown successfully to cover all continents. Our passion is innovative sealing solutions, and our goal is to make our world a safer place.

- Extensive R&D resources and advanced test facilities
- Inventor of Multidiameter™
- Customers in more than 80 markets

Learn more online

Feel free to visit roxtec.com/ug, where you can find useful product information such as installation instructions and educational videos on our sealing solutions for underground applications. Via roxtec.com you can also access our free, web-based engineering tool Roxtec Transit Designer™.